

## Maßbuchstaben und Formelzeichen

Bauform	Werksnorm	Einzelteil		Seite	
Radiallager (außer Kegelrollenlager) metrisch	WN001 - 1 / P0	<a href="#">IR</a>	<a href="#">AR</a>	5	6
	WN001 - 1 / P6	<a href="#">IR</a>	<a href="#">AR</a>	7	8
	WN001 - 1 / P5	<a href="#">IR</a>	<a href="#">AR</a>	9	10
	WN001 - 1 / P4	<a href="#">IR</a>	<a href="#">AR</a>	11	12
	WN001 - 1 / P2	<a href="#">IR</a>	<a href="#">AR</a>	13	14
	WN001 - 1 / SP	<a href="#">IR</a>	<a href="#">AR</a>	15	16
	WN001 - 1 / UP	<a href="#">IR</a>	<a href="#">AR</a>	17	18
Radiallager (außer Kegelrollenlager) zöllig	WN001 - 2 / P0	<a href="#">IR</a>	<a href="#">AR</a>	19	20
Kegelrollenlager metrisch	WN001 - 3 / P0	<a href="#">IR</a>	<a href="#">AR</a>	21	22
	WN001 - 3 / P6X	<a href="#">IR</a>	<a href="#">AR</a>	23	24
	WN001 - 3 / P5	<a href="#">IR</a>	<a href="#">AR</a>	25	26
	WN001 - 3 / P4	<a href="#">IR</a>	<a href="#">AR</a>	27	28
	WN001 - 3 / P2	<a href="#">IR</a>	<a href="#">AR</a>	29	30
	WN001 - 3 / CL7C	<a href="#">IR</a>	<a href="#">AR</a>	31	32
	WN001 - 3 / CLN	<a href="#">IR</a>	<a href="#">AR</a>	33	34
Kegelrollenlager zöllig	WN001 - 4 / P0	<a href="#">IR</a>	<a href="#">AR</a>	35	36
	WN001 - 4 / CL2	<a href="#">IR</a>	<a href="#">AR</a>	37	38
	WN001 - 4 / CL3	<a href="#">IR</a>	<a href="#">AR</a>	39	40
	WN001 - 4 / CL0	<a href="#">IR</a>	<a href="#">AR</a>	41	42
Kegelige Bohrung 1:12	WN001 - 5 / P0	<a href="#">IR</a>		43	
	WN001 - 5 / P6	<a href="#">IR</a>		44	
	WN001 - 5 / P5	<a href="#">IR</a>		45	
	WN001 - 5 / SP	<a href="#">IR</a>		46	
	WN001 - 5 / UP	<a href="#">IR</a>		47	
Kegelige Bohrung 1:30	WN001 - 6 / P0	<a href="#">IR</a>		48	

Symbol	Definition
<b>d</b>	Nenndurchmesser der Bohrung
<b>d<sub>1</sub></b>	Durchmesser der theoretischen Kegelfläche am weiten Ende der kegeligen Bohrung
<b>Δ<sub>ds</sub></b>	Abweichung eines einzelnen Bohrungsdurchmessers
<b>Δ<sub>dmp</sub></b>	Abweichung des mittleren Bohrungsdurchmessers in einer Ebene
<b>Δ<sub>d1mp</sub></b>	Abweichung des mittleren Bohrungsdurchmessers für theoretische Kegelflächen am weiten Ende einer kegeligen Bohrung
<b>V<sub>dp</sub></b>	Schwankung des Bohrungsdurchmessers in einer radialen Ebene
<b>V<sub>dmp</sub></b>	Schwankung des mittleren Bohrungsdurchmessers
<b>α</b>	Nennkegelwinkel
<b>D</b>	Nennaußendurchmesser
<b>D<sub>1</sub></b>	Flanschaußendurchmesser
<b>Δ<sub>Ds</sub></b>	Abweichung eines einzelnen Außendurchmessers
<b>Δ<sub>Dmp</sub></b>	Abweichung eines mittleren Außendurchmessers in einer Ebene
<b>V<sub>Dp</sub></b>	Schwankung des Außendurchmessers in einer einzelnen radialen Ebene
<b>V<sub>Dmp</sub></b>	Schwankung des mittleren Außendurchmessers
<b>B</b>	Nennbreite des Innenringes
<b>Δ<sub>Bs</sub></b>	Abweichung einer einzelnen Innenringbreite
<b>V<sub>Bs</sub></b>	Schwankung der Innenringbreite
<b>C</b>	Nennbreite des Außenringes
<b>C<sub>1</sub></b>	Flanschbreite
<b>Δ<sub>Cs</sub></b>	Abweichung einer einzelnen Außenringbreite
<b>Δ<sub>C1s</sub></b>	Abweichung einer einzelnen Flanschbreite
<b>V<sub>Cs</sub></b>	Schwankung der Außenringbreite
<b>V<sub>C1s</sub></b>	Schwankung der Flanschbreite
<b>K<sub>ia</sub></b>	Rundlauf des Innenringes am zusammengebauten Lager
<b>K<sub>ea</sub></b>	Rundlauf des Außenringes am zusammengebauten Lager
<b>S<sub>d</sub></b>	Planlauf der Stirnseite in Bezug auf die Bohrung
<b>S<sub>D</sub></b>	Schwankung der Neigung der Mantellinie, bezogen auf die Bezugsseitenfläche
<b>S<sub>D1</sub></b>	Schwankung der Neigung der Mantellinie, bezogen auf die Flanschstirnseite
<b>S<sub>ia</sub></b>	Planlauf der Stirnseite in Bezug auf die Laufbahn des Innenringes am zusammengebauten Lager
<b>S<sub>ea</sub></b>	Planlauf der Stirnseite in Bezug auf die Laufbahn des Außenringes am zusammengebauten Lager
<b>S<sub>ea1</sub></b>	Planlauf der Flanschstirnseite in Bezug auf die Laufbahn des Außenringes am zusammengebauten Lager

**Veranschaulichung**

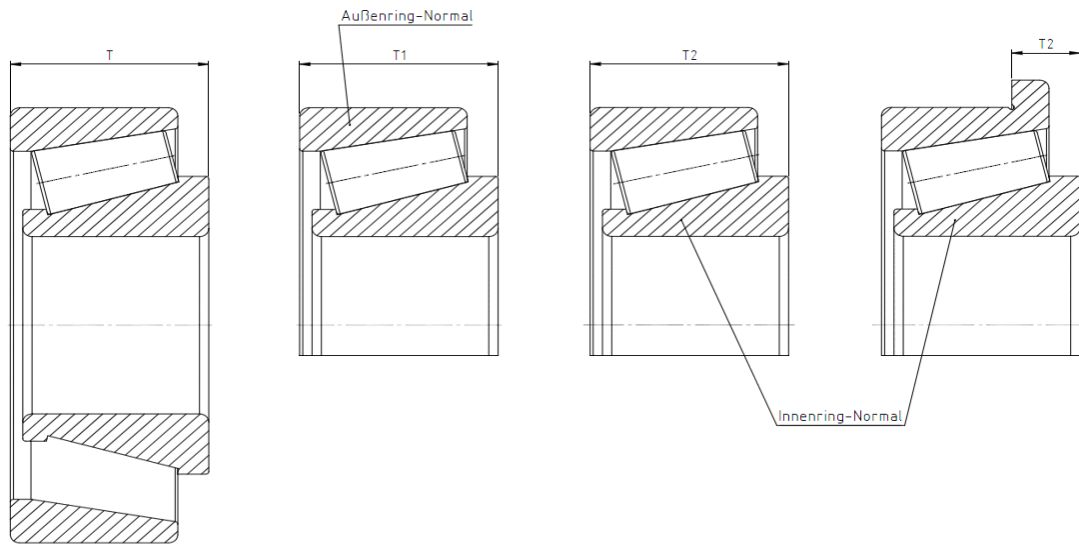
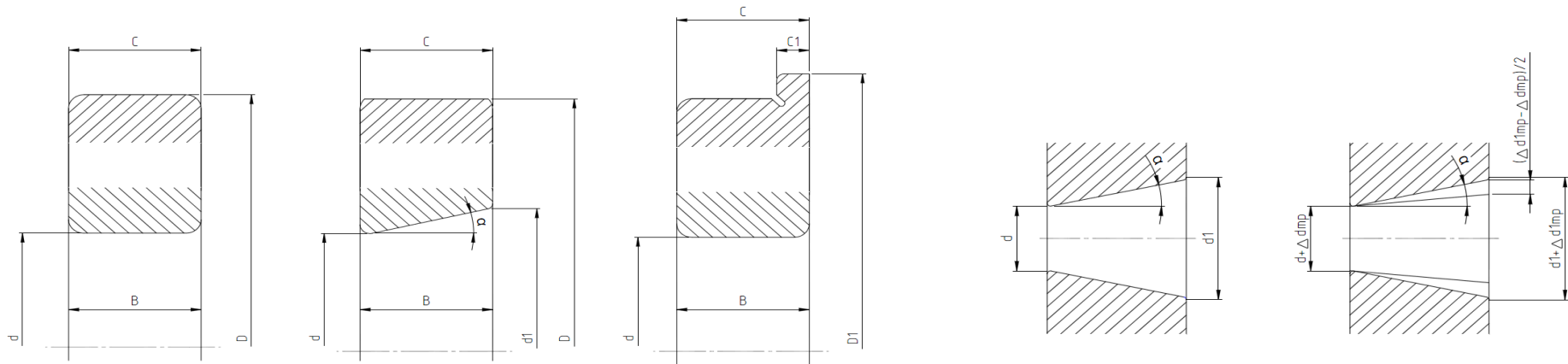

# WN001 - 1 / P0

## Radiallager (außer Kegelrollenlager) - metrisch

Innenring																								
d		$\Delta_{dmp}$		$\Delta_{ds}$		$V_{dp}$										$V_{dmp}$	$K_{ia}$	$S_{ia}$	$S_d$	$\Delta_{Bs}$		$\Delta_{B1s}^{1)}$		$V_{Bs}$
über	bis	ob.	unt.	ob.	unt.	0	1	2	3	4	5	6	7	8	9	max.	max.	max.	max.	ob.	unt.	ob.	unt.	max.
mm		$\mu m$		$\mu m$		$\mu m$										$\mu m$	$\mu m$	$\mu m$	$\mu m$	$\mu m$		$\mu m$		$\mu m$
0	0,6	0	-8	-	-	8	8	6	6	6	-	-	-	-	10	6	10	-	-	0	-40	-	-	12
0,6	2,5	0	-8	-	-	8	8	6	6	6	-	-	10	10	10	6	10	-	-	0	-40	-	-	12
2,5	10	0	-8	-	-	8	8	6	6	6	-	-	10	10	10	6	10	-	-	0	-120	0	-250	15
10	18	0	-8	-	-	8	8	6	6	6	-	-	10	10	10	6	10	-	-	0	-120	0	-250	20
18	30	0	-10	-	-	10	10	8	8	8	-	-	13	13	13	8	13	-	-	0	-120	0	-250	20
30	50	0	-12	-	-	12	12	9	9	9	-	-	15	15	15	9	15	-	-	0	-120	0	-250	20
50	80	0	-15	-	-	19	19	11	11	11	-	-	19	19	19	11	20	-	-	0	-150	0	-380	25
80	120	0	-20	-	-	25	25	15	15	15	-	-	25	25	25	15	25	-	-	0	-200	0	-380	25
120	180	0	-25	-	-	31	31	19	19	19	-	-	31	31	31	19	30	-	-	0	-250	0	-500	30
180	250	0	-30	-	-	38	38	23	23	23	-	-	38	38	38	23	40	-	-	0	-300	0	-500	30
250	315	0	-35	-	-	44	44	26	26	26	-	-	44	44	44	26	50	-	-	0	-350	0	-500	35
315	400	0	-40	-	-	50	50	30	30	30	-	-	50	50	50	30	60	-	-	0	-400	0	-630	40
400	500	0	-45	-	-	56	56	34	34	34	-	-	56	56	56	34	65	-	-	0	-450	-	-	50
500	630	0	-50	-	-	63	63	38	38	38	-	-	63	63	63	38	70	-	-	0	-500	-	-	60
630	800	0	-75	-	-	-	-	-	-	-	-	-	-	-	-	-	80	-	-	0	-750	-	-	70
800	1000	0	-100	-	-	-	-	-	-	-	-	-	-	-	-	-	90	-	-	0	-1000	-	-	80
1000	1250	0	-125	-	-	-	-	-	-	-	-	-	-	-	-	-	100	-	-	0	-1250	-	-	100
1250	1600	0	-160	-	-	-	-	-	-	-	-	-	-	-	-	-	120	-	-	0	-1600	-	-	120
1600	2000	0	-200	-	-	-	-	-	-	-	-	-	-	-	-	-	140	-	-	0	-2000	-	-	140
2000	2500	0	-250	-	-	-	-	-	-	-	-	-	-	-	-	-	160	-	-	0	-2500	-	-	160
2500	3150	0	-300	-	-	-	-	-	-	-	-	-	-	-	-	-	180	-	-	0	-3000	-	-	190
3150	4000	0	-400	-	-	-	-	-	-	-	-	-	-	-	-	-	200	-	-	0	-4000	-	-	230
4000	5000	0	-500	-	-	-	-	-	-	-	-	-	-	-	-	-	230	-	-	0	-5000	-	-	270

1) Nur für Lager, die speziell für gepaarte Anordnungen gefertigt werden.

Die Toleranzen innerhalb des gekennzeichneten Bereichs entspricht DIN 620 - 2 / P0

# WN001 - 1 / P0

## Radiallager (außer Kegelrollenlager) - metrisch

Außenring																										
D		$\Delta_{Dmp}$		$\Delta_{Ds}$		$V_{Dp}^{1)}$											$V_{Dmp}^{1)}$	$K_{ea}$	$S_{ea}$	$S_D$	$\Delta_{Cs}$		$V_{Cs}$			
über	bis	ob.	unt.	ob.	unt.	0	1	2	3	4	7	8	9	2	3	4	max.	max.	max.	max.	ob.	unt.	max.			
mm		$\mu m$		$\mu m$		offen											abgedichtet <sup>2)</sup>			$\mu m$	$\mu m$	$\mu m$	$\mu m$	$\mu m$		$\mu m$
0	0,6	0	-8	-	-	8	8	6	6	6	-	-	10	10	10	10	6	15	-	-	-	-	-			
0,6	2,5	0	-8	-	-	8	8	6	6	6	10	10	10	10	10	10	6	15	-	-	-	-	-			
2,5	6	0	-8	-	-	8	8	6	6	6	10	10	10	10	10	10	6	15	-	-	-	-	-			
6	18	0	-9	-	-	9	9	7	7	7	12	12	12	12	12	12	7	15	-	-	-	-	-			
18	30	0	-9	-	-	9	9	7	7	7	12	12	12	12	12	12	7	15	-	-	-	-	-			
30	50	0	-11	-	-	11	11	8	8	8	14	14	14	16	16	16	8	20	-	-	-	-	-			
50	80	0	-13	-	-	13	13	10	10	10	16	16	16	20	20	20	10	25	-	-	-	-	-			
80	120	0	-15	-	-	19	19	11	11	11	19	19	19	26	26	26	11	35	-	-	-	-	-			
120	150	0	-18	-	-	23	23	14	14	14	23	23	23	30	30	30	14	40	-	-	-	-	-			
150	180	0	-25	-	-	31	31	19	19	19	31	31	31	38	38	38	19	45	-	-	-	-	-			
180	250	0	-30	-	-	38	38	23	23	23	38	38	38	-	-	-	23	50	-	-	-	-	-			
250	315	0	-35	-	-	44	44	26	26	26	44	44	44	-	-	-	26	60	-	-	-	-	-			
315	400	0	-40	-	-	50	50	30	30	30	50	50	50	-	-	-	30	70	-	-	-	-	-			
400	500	0	-45	-	-	56	56	34	34	34	56	56	56	-	-	-	34	80	-	-	-	-	-			
500	630	0	-50	-	-	63	63	38	38	38	63	63	63	-	-	-	38	100	-	-	-	-	-			
630	800	0	-75	-	-	94	94	55	55	55	94	94	94	-	-	-	55	120	-	-	-	-	-			
800	1000	0	-100	-	-	125	125	75	75	75	125	125	125	-	-	-	75	140	-	-	-	-	-			
1000	1250	0	-125	-	-	-	-	-	-	-	-	-	-	-	-	-	-	160	-	-	-	-	-			
1250	1600	0	-160	-	-	-	-	-	-	-	-	-	-	-	-	-	-	190	-	-	-	-	-			
1600	2000	0	-200	-	-	-	-	-	-	-	-	-	-	-	-	-	-	220	-	-	-	-	-			
2000	2500	0	-250	-	-	-	-	-	-	-	-	-	-	-	-	-	-	250	-	-	-	-	-			
2500	3150	0	-300	-	-	-	-	-	-	-	-	-	-	-	-	-	-	300	-	-	-	-	-			
3150	4000	0	-400	-	-	-	-	-	-	-	-	-	-	-	-	-	-	350	-	-	-	-	-			
4000	5000	0	-500	-	-	-	-	-	-	-	-	-	-	-	-	-	-	400	-	-	-	-	-			

1) Gilt vor dem Zusammenbau des Lagers und nachdem innere und / oder äußere Sprengringe entfernt sind.

2) Abgedichtete Lager sind Lager mit Deckscheibe oder mit Dichtung.

Die Toleranzen innerhalb des gekennzeichneten Bereichs entspricht DIN 620 - 2 / P0

# WN001 - 1 / P6

## Radiallager (außer Kegelrollenlager) - metrisch

Innenring																								
d		$\Delta_{dmp}$		$\Delta_{ds}$		$V_{dp}$										$V_{dmp}$	$K_{ia}$	$S_{ia}$	$S_d$	$\Delta_{Bs}$		$\Delta_{B1s}^{1)}$		$V_{Bs}$
über	bis	ob.	unt.	ob.	unt.	0	1	2	3	4	5	6	7	8	9	max.	max.	max.	max.	ob.	unt.	ob.	unt.	max.
mm		$\mu m$		$\mu m$		$\mu m$										$\mu m$	$\mu m$	$\mu m$	$\mu m$	$\mu m$		$\mu m$		$\mu m$
0	0,6	0	-7	-	-	7	7	5	5	5	-	-	-	-	9	5	5	-	-	0	-40	-	-	12
0,6	2,5	0	-7	-	-	7	7	5	5	5	-	-	9	9	9	5	5	-	-	0	-40	-	-	12
2,5	10	0	-7	-	-	7	7	5	5	5	-	-	9	9	9	5	6	-	-	0	-120	0	-250	15
10	18	0	-7	-	-	7	7	5	5	5	-	-	9	9	9	5	7	-	-	0	-120	0	-250	20
18	30	0	-8	-	-	8	8	6	6	6	-	-	10	10	10	6	8	-	-	0	-120	0	-250	20
30	50	0	-10	-	-	10	10	8	8	8	-	-	13	13	13	8	10	-	-	0	-120	0	-250	20
50	80	0	-12	-	-	15	15	9	9	9	-	-	15	15	15	9	10	-	-	0	-150	0	-380	25
80	120	0	-15	-	-	19	19	11	11	11	-	-	19	19	19	11	13	-	-	0	-200	0	-380	25
120	180	0	-18	-	-	23	23	14	14	14	-	-	23	23	23	14	18	-	-	0	-250	0	-500	30
180	250	0	-22	-	-	28	28	17	17	17	-	-	28	28	28	17	20	-	-	0	-300	0	-500	30
250	315	0	-25	-	-	31	31	19	19	19	-	-	31	31	31	19	25	-	-	0	-350	0	-500	35
315	400	0	-30	-	-	38	38	23	23	23	-	-	38	38	38	23	30	-	-	0	-400	0	-630	40
400	500	0	-35	-	-	44	44	26	26	26	-	-	44	44	44	26	35	-	-	0	-450	0	-630	45
500	630	0	-40	-	-	50	50	30	30	30	-	-	50	50	50	30	40	-	-	0	-500	0	-800	50
630	800	0	-50	-	-	-	-	-	-	-	-	-	-	-	-	-	45	-	-	0	-750	-	-	55
800	1000	0	-60	-	-	-	-	-	-	-	-	-	-	-	-	-	50	-	-	0	-1000	-	-	60
1000	1250	0	-75	-	-	-	-	-	-	-	-	-	-	-	-	-	60	-	-	0	-1250	-	-	70
1250	1600	0	-90	-	-	-	-	-	-	-	-	-	-	-	-	-	70	-	-	0	-1600	-	-	70
1600	2000	0	-115	-	-	-	-	-	-	-	-	-	-	-	-	-	80	-	-	0	-2000	-	-	80
2000	2500	0	-135	-	-	-	-	-	-	-	-	-	-	-	-	-	90	-	-	0	-2500	-	-	120

1) Nur für Lager, die speziell für gepaarte Anordnungen gefertigt werden.

Die Toleranzen innerhalb des gekennzeichneten Bereichs entspricht DIN 620 - 2 / P6

# WN001 - 1 / P6

## Radiallager (außer Kegelrollenlager) - metrisch

Außenring																										
D		$\Delta_{Dmp}$		$\Delta_{Ds}$		$V_{Dp}^{1)}$											$V_{Dmp}^{1)}$	$K_{ea}$	$S_{ea}$	$S_D$	$\Delta_{Cs}$		$V_{Cs}$			
über	bis	ob.	unt.	ob.	unt.	0	1	2	3	4	7	8	9	2	3	4	max.	max.	max.	max.	ob.	unt.	max.			
mm		$\mu m$		$\mu m$		offen											abgedichtet <sup>2)</sup>			$\mu m$	$\mu m$	$\mu m$	$\mu m$	$\mu m$		$\mu m$
0	2,5	0	-7	-	-	7	7	5	5	5	-	-	9	9	9	9	5	8	-	-	-	-				
2,5	6	0	-7	-	-	7	7	5	5	5	9	9	9	9	9	9	5	8	-	-	-	-				
6	18	0	-7	-	-	7	7	5	5	5	9	9	9	9	9	9	5	8	-	-	Identisch mit					
18	30	0	-8	-	-	8	8	6	6	6	10	10	10	10	10	10	6	9	-	-	$\Delta Bs$ und $VBs$					
30	50	0	-9	-	-	9	9	7	7	7	11	11	11	13	13	13	7	10	-	-	für Innenring					
50	80	0	-11	-	-	11	11	8	8	8	14	14	14	16	16	16	8	13	-	-	desselben Lagers					
80	120	0	-13	-	-	16	16	10	10	10	16	16	16	20	20	20	10	18	-	-	-	-				
120	150	0	-15	-	-	19	19	11	11	11	19	19	19	25	25	25	11	20	-	-	-	-				
150	180	0	-18	-	-	23	23	14	14	14	23	23	23	30	30	30	14	23	-	-	-	-				
180	250	0	-20	-	-	25	25	15	15	15	25	25	25	-	-	-	15	25	-	-	-	-				
250	315	0	-25	-	-	31	31	19	19	19	31	31	31	-	-	-	19	30	-	-	-	-				
315	400	0	-28	-	-	35	35	21	21	21	35	35	35	-	-	-	21	35	-	-	-	-				
400	500	0	-33	-	-	41	41	25	25	25	41	41	41	-	-	-	25	40	-	-	-	-				
500	630	0	-38	-	-	48	48	29	29	29	48	48	48	-	-	-	29	50	-	-	-	-				
630	800	0	-45	-	-	56	56	34	34	34	56	56	56	-	-	-	34	60	-	-	-	-				
800	1000	0	-60	-	-	75	75	45	45	45	75	75	75	-	-	-	45	75	-	-	-	-				
1000	1250	0	-75	-	-	-	-	-	-	-	-	-	-	-	-	-	-	85	-	-	-	-				
1250	1600	0	-90	-	-	-	-	-	-	-	-	-	-	-	-	-	-	100	-	-	-	-				
1600	2000	0	-115	-	-	-	-	-	-	-	-	-	-	-	-	-	-	100	-	-	-	-				
2000	2500	0	-135	-	-	-	-	-	-	-	-	-	-	-	-	-	-	120	-	-	-	-				

1) Gilt vor dem Zusammenbau des Lagers und nachdem innere und / oder äußere Sprenringe entfernt sind.

2) Abgedichtete Lager sind Lager mit Deckscheibe oder mit Dichtung.

Die Toleranzen innerhalb des gekennzeichneten Bereichs entspricht DIN 620 - 2 / P6



# WN001 - 1 / P5

## Radiallager (außer Kegelrollenlager) - metrisch

Innenring																								
d		$\Delta_{dmp}$		$\Delta_{ds}$		$V_{dp}$										$V_{dmp}$	$K_{ia}$	$S_{ia}^{1)}$	$S_d$	$\Delta_{Bs}$		$\Delta_{B1s}^{2)}$		$V_{Bs}$
über	bis	ob.	unt.	ob.	unt.	0	1	2	3	4	5	6	7	8	9	max.	max.	max.	max.	ob.	unt.	ob.	unt.	max.
mm		$\mu m$		$\mu m$		$\mu m$										$\mu m$	$\mu m$	$\mu m$	$\mu m$	$\mu m$		$\mu m$		$\mu m$
0	0,6	0	-5	-	-	4	4	4	4	4	-	-	-	-	5	3	4	7	7	0	-40	0	-250	5
0,6	2,5	0	-5	-	-	4	4	4	4	4	-	-	5	5	5	3	4	7	7	0	-40	0	-250	5
2,5	10	0	-5	-	-	4	4	4	4	4	-	-	5	5	5	3	4	7	7	0	-40	0	-250	5
10	18	0	-5	-	-	4	4	4	4	4	-	-	5	5	5	3	4	7	7	0	-80	0	-250	5
18	30	0	-6	-	-	5	5	5	5	5	-	-	6	6	6	3	4	8	8	0	-120	0	-250	5
30	50	0	-8	-	-	6	6	6	6	6	-	-	8	8	8	4	5	8	8	0	-120	0	-250	5
50	80	0	-9	-	-	7	7	7	7	7	-	-	9	9	9	5	5	8	8	0	-150	0	-250	6
80	120	0	-10	-	-	8	8	8	8	8	-	-	10	10	10	5	6	9	9	0	-200	0	-380	7
120	180	0	-13	-	-	10	10	10	10	10	-	-	13	13	13	7	8	10	10	0	-250	0	-380	8
180	250	0	-15	-	-	12	12	12	12	12	-	-	15	15	15	8	10	13	11	0	-300	0	-500	10
250	315	0	-18	-	-	14	14	14	14	14	-	-	18	18	18	9	13	15	13	0	-350	0	-500	13
315	400	0	-23	-	-	18	18	18	18	18	-	-	23	23	23	12	15	20	15	0	-400	0	-630	15
400	500	0	-28	-	-	21	21	21	21	21	-	-	28	28	28	14	17	23	18	0	-450	0	-630	18
500	630	0	-35	-	-	26	26	26	26	26	-	-	35	35	35	18	19	25	20	0	-500	0	-800	20
630	800	0	-45	-	-	-	-	-	-	-	-	-	-	-	-	-	22	30	26	0	-750	-	-	26
800	1000	0	-60	-	-	-	-	-	-	-	-	-	-	-	-	-	26	30	32	0	-1000	-	-	32
1000	1250	0	-75	-	-	-	-	-	-	-	-	-	-	-	-	-	30	30	38	0	-1250	-	-	38
1250	1600	0	-90	-	-	-	-	-	-	-	-	-	-	-	-	-	35	30	45	0	-1600	-	-	45
1600	2000	0	-115	-	-	-	-	-	-	-	-	-	-	-	-	-	40	30	55	0	-2000	-	-	55

1) Nur für Rillenkugellager.

2) Nur für Lager, die speziell für gepaarte Anordnungen gefertigt werden.

Die Toleranzen innerhalb des gekennzeichneten Bereichs entspricht DIN 620 - 2 / P5

# WN001 - 1 / P5

## Radiallager (außer Kegelrollenlager) - metrisch

Außenring																										
D		$\Delta_{Dmp}$		$\Delta_{Ds}$		$V_{Dp}$											$V_{Dmp}$	$K_{ea}$	$S_{ea}^{2)}$	$S_D$	$\Delta_{Cs}$		$V_{Cs}$			
über	bis	ob.	unt.	ob.	unt.	0	1	2	3	4	7	8	9	2	3	4	max.	max.	max.	max.	ob.	unt.	max.			
mm		$\mu m$		$\mu m$		offen											abgedichtet <sup>1)</sup>			$\mu m$	$\mu m$	$\mu m$	$\mu m$	$\mu m$		$\mu m$
0	2,5	0	-5	-	-	4	4	4	4	4	-	-	5	-	-	-	3	5	8	4	-	-	5			
2,5	6	0	-5	-	-	4	4	4	4	4	5	5	5	-	-	-	3	5	8	8	-	-	5			
6	18	0	-5	-	-	4	4	4	4	4	5	5	5	-	-	-	3	5	8	8	Identisch mit		5			
18	30	0	-6	-	-	5	5	5	5	5	6	6	6	-	-	-	3	6	8	8	$\Delta Bs$ für den		5			
30	50	0	-7	-	-	5	5	5	5	5	7	7	7	-	-	-	4	7	8	8	Innenring		5			
50	80	0	-9	-	-	7	7	7	7	7	9	9	9	-	-	-	5	8	10	8	desselben		6			
80	120	0	-10	-	-	8	8	8	8	8	10	10	10	-	-	-	5	10	11	9	Lagers		8			
120	150	0	-11	-	-	8	8	8	8	8	11	11	11	-	-	-	6	11	13	10	-	-	8			
150	180	0	-13	-	-	10	10	10	10	10	13	13	13	-	-	-	7	13	14	10	-	-	8			
180	250	0	-15	-	-	11	11	11	11	11	15	15	15	-	-	-	8	15	15	11	-	-	10			
250	315	0	-18	-	-	14	14	14	14	14	18	18	18	-	-	-	9	18	18	13	-	-	11			
315	400	0	-20	-	-	15	15	15	15	15	20	20	20	-	-	-	10	20	20	13	-	-	13			
400	500	0	-23	-	-	17	17	17	17	17	23	23	23	-	-	-	12	23	23	15	-	-	15			
500	630	0	-28	-	-	21	21	21	21	21	28	28	28	-	-	-	14	25	25	18	-	-	18			
630	800	0	-35	-	-	26	26	26	26	26	35	35	35	-	-	-	18	30	30	20	-	-	20			
800	1000	0	-50	-	-	29	29	29	29	29	50	50	50	-	-	-	25	35	35	25	-	-	25			
1000	1250	0	-63	-	-	-	-	-	-	-	-	-	-	-	-	-	-	40	45	30	-	-	30			
1250	1600	0	-80	-	-	-	-	-	-	-	-	-	-	-	-	-	-	45	55	35	-	-	35			
1600	2000	0	-100	-	-	-	-	-	-	-	-	-	-	-	-	-	-	55	55	40	-	-	38			
2000	2500	0	-125	-	-	-	-	-	-	-	-	-	-	-	-	-	-	65	55	50	-	-	45			

1) Für Lager mit Deck- oder Dichtscheiben sind keine Werte festgelegt.

2) Nur für Rillenkugellager.

Die Toleranzen innerhalb des gekennzeichneten Bereichs entspricht DIN 620 - 2 / P5

# WN001 - 1 / P4

## Radiallager (außer Kegelrollenlager) - metrisch

Innenring																								
d		$\Delta_{dmp}$		$\Delta_{ds}$		$V_{dp}$										$V_{dmp}$	$K_{ia}$	$S_{ia}^{1)}$	$S_d$	$\Delta_{Bs}$		$\Delta_{B1s}^{2)}$		$V_{Bs}$
über	bis	ob.	unt.	ob.	unt.	0	1	2	3	4	5	6	7	8	9	max.	max.	max.	max.	ob.	unt.	ob.	unt.	max.
mm		$\mu m$		$\mu m$		$\mu m$										$\mu m$	$\mu m$	$\mu m$	$\mu m$	$\mu m$		$\mu m$		$\mu m$
0	0,6	0	-4	-	-	3	3	3	3	-	-	-	-	-	4	2	2,5	3	3	0	-40	0	-250	2,5
0,6	2,5	0	-4	0	-4	3	3	3	3	-	-	-	4	4	4	2	2,5	3	3	0	-40	0	-250	2,5
2,5	10	0	-4	0	-4	3	3	3	3	-	-	-	4	4	4	2	2,5	3	3	0	-40	0	-250	2,5
10	18	0	-4	0	-4	3	3	3	3	-	-	-	4	4	4	2	2,5	3	3	0	-80	0	-250	2,5
18	30	0	-5	0	-5	4	4	4	4	-	-	-	5	5	5	2,5	3	4	4	0	-120	0	-250	2,5
30	50	0	-6	0	-6	5	5	5	5	-	-	-	6	6	6	3	4	4	4	0	-120	0	-250	3
50	80	0	-7	0	-7	5	5	5	5	-	-	-	7	7	7	3,5	4	5	5	0	-150	0	-250	4
80	120	0	-8	0	-8	6	6	6	6	-	-	-	8	8	8	4	5	5	5	0	-200	0	-380	4
120	180	0	-10	0	-10	8	8	8	8	-	-	-	10	10	10	5	6	7	6	0	-250	0	-380	5
180	250	0	-12	0	-12	9	9	9	9	-	-	-	12	12	12	6	8	8	7	0	-300	0	-500	6
250	315	0	-15	0	-15	-	-	-	-	-	-	-	-	-	-	-	8	10	7	0	-350	0	-500	7
315	400	0	-19	0	-19	-	-	-	-	-	-	-	-	-	-	-	10	12	8	0	-400	-	-	8
400	500	0	-23	0	-23	-	-	-	-	-	-	-	-	-	-	-	10	13	9	0	-450	-	-	9
500	630	0	-26	0	-26	-	-	-	-	-	-	-	-	-	-	-	12	15	10	0	-500	-	-	10
630	800	0	-32	0	-32	-	-	-	-	-	-	-	-	-	-	-	15	20	15	0	-750	-	-	15
800	1000	0	-40	-	-	-	-	-	-	-	-	-	-	-	-	-	20	25	21	0	-1000	-	-	21

1) Nur für Rillenkugellager.

2) Nur für Lager, die speziell für gepaarte Anordnungen gefertigt werden.

Die Toleranzen innerhalb des gekennzeichneten Bereichs entspricht DIN 620 - 2 / P4

# WN001 - 1 / P4

## Radiallager (außer Kegelrollenlager) - metrisch

Außenring																										
D		$\Delta_{Dmp}$		$\Delta_{Ds}$		$V_{Dp}$											$V_{Dmp}$	$K_{ea}$	$S_{ea}^{2)}$	$S_D$	$\Delta_{Cs}$		$V_{Cs}$			
über	bis	ob.	unt.	ob.	unt.	0	1	2	3	4	7	8	9	2	3	4	max.	max.	max.	max.	ob.	unt.	max.			
mm		$\mu m$		$\mu m$		offen											abgedichtet <sup>1)</sup>			$\mu m$	$\mu m$	$\mu m$	$\mu m$	$\mu m$		$\mu m$
0	2,5	0	-4	-	-	3	3	3	3	3	-	-	4	-	-	-	2	3	5	2	-	-	2,5			
2,5	6	0	-4	0	-4	3	3	3	3	3	4	4	4	-	-	-	2	3	5	4	-	-	2,5			
6	18	0	-4	0	-4	3	3	3	3	3	4	4	4	-	-	-	2	3	5	4	Identisch mit		2,5			
18	30	0	-5	0	-5	4	4	4	4	4	5	5	5	-	-	-	2,5	4	5	4	$\Delta Bs$ für den		2,5			
30	50	0	-6	0	-6	5	5	5	5	5	6	6	6	-	-	-	3	5	5	4	Innenring		2,5			
50	80	0	-7	0	-7	5	5	5	5	5	7	7	7	-	-	-	3,5	5	5	4	desselben		3			
80	120	0	-8	0	-8	6	6	6	6	6	8	8	8	-	-	-	4	6	6	5	Lagers		4			
120	150	0	-9	0	-9	7	7	7	7	7	9	9	9	-	-	-	5	7	7	5	-	-	5			
150	180	0	-10	0	-10	8	8	8	8	8	10	10	10	-	-	-	5	8	8	5	-	-	5			
180	250	0	-11	0	-11	8	8	8	8	8	11	11	11	-	-	-	6	10	10	7	-	-	7			
250	315	0	-13	0	-13	10	10	10	10	10	13	13	13	-	-	-	7	11	10	8	-	-	7			
315	400	0	-15	0	-15	11	11	11	11	11	15	15	15	-	-	-	8	13	13	10	-	-	8			
400	500	0	-20	0	-20	-	-	-	-	-	-	-	-	-	-	-	-	14	15	10	-	-	9			
500	630	0	-25	0	-25	-	-	-	-	-	-	-	-	-	-	-	-	17	18	12	-	-	10			
630	800	0	-28	0	-28	-	-	-	-	-	-	-	-	-	-	-	-	20	22	14	-	-	12			
800	1000	0	-35	0	-35	-	-	-	-	-	-	-	-	-	-	-	-	25	28	20	-	-	15			
1000	1250	0	-40	0	-40	-	-	-	-	-	-	-	-	-	-	-	-	30	35	25	-	-	20			
1250	1600	0	-55	0	-55	-	-	-	-	-	-	-	-	-	-	-	-	40	45	30	-	-	25			

1) Für Lager mit Deck- oder Dichtscheiben sind keine Werte festgelegt.

2) Nur für Rillenkugellager.

Die Toleranzen innerhalb des gekennzeichneten Bereichs entspricht DIN 620 - 2 / P4

# WN001 - 1 / P2

## Radiallager (außer Kegelrollenlager) - metrisch

Innenring																								
d		$\Delta_{dmp}$		$\Delta_{ds}$		$V_{dp}$										$V_{dmp}$	$K_{ia}$	$S_{ia}^{1)}$	$S_d$	$\Delta_{Bs}$		$\Delta_{B1s}$		$V_{Bs}$
über	bis	ob.	unt.	ob.	unt.	0	1	2	3	4	5	6	7	8	9	max.	max.	max.	max.	ob.	unt.	ob.	unt.	max.
mm		$\mu m$		$\mu m$		$\mu m$										$\mu m$	$\mu m$	$\mu m$	$\mu m$	$\mu m$		$\mu m$		$\mu m$
0	0,6	0	-2,5	-	-	2,5	2,5	2,5	2,5	2,5	2,5	2,5	2,5	2,5	2,5	1,5	1,5	1,5	1,5	0	-40	-	-	1,5
0,6	2,5	0	-2,5	0	-2,5	2,5	2,5	2,5	2,5	2,5	2,5	2,5	2,5	2,5	2,5	1,5	1,5	1,5	1,5	0	-40	-	-	1,5
2,5	10	0	-2,5	0	-2,5	2,5	2,5	2,5	2,5	2,5	2,5	2,5	2,5	2,5	2,5	1,5	1,5	1,5	1,5	0	-40	-	-	1,5
10	18	0	-2,5	0	-2,5	2,5	2,5	2,5	2,5	2,5	2,5	2,5	2,5	2,5	2,5	1,5	1,5	1,5	1,5	0	-80	-	-	1,5
18	30	0	-2,5	0	-2,5	2,5	2,5	2,5	2,5	2,5	2,5	2,5	2,5	2,5	2,5	1,5	2,5	2,5	1,5	0	-120	-	-	1,5
30	50	0	-2,5	0	-2,5	2,5	2,5	2,5	2,5	2,5	2,5	2,5	2,5	2,5	2,5	1,5	2,5	2,5	1,5	0	-120	-	-	1,5
50	80	0	-4	0	-4	4	4	4	4	4	4	4	4	4	4	2	2,5	2,5	1,5	0	-150	-	-	1,5
80	120	0	-5	0	-5	5	5	5	5	5	5	5	5	5	5	2,5	2,5	2,5	2,5	0	-200	-	-	2,5
120	150	0	-7	0	-7	7	7	7	7	7	7	7	7	7	7	3,5	2,5	2,5	2,5	0	-250	-	-	2,5
150	180	0	-7	0	-7	7	7	7	7	7	7	7	7	7	7	3,5	5	5	4	0	-300	-	-	4
180	250	0	-8	0	-8	8	8	8	8	8	8	8	8	8	8	4	5	5	5	0	-350	-	-	5

1) Nur für Rillenkugellager.

Die Toleranzen innerhalb des gekennzeichneten Bereichs entspricht DIN 620 - 2 / P2

## WN001 - 1 / P2

### Radiallager (außer Kegelrollenlager) - metrisch

Außenring																										
D		$\Delta_{Dmp}$		$\Delta_{Ds}$		$V_{Dp}$											$V_{Dmp}$	$K_{ea}$	$S_{ea}^{2)}$	$S_D$	$\Delta_{Cs}$		$V_{Cs}$			
über	bis	ob.	unt.	ob.	unt.	0	1	2	3	4	7	8	9	2	3	4	max.	max.	max.	max.	ob.	unt.	max.			
mm		$\mu m$		$\mu m$		offen											abgedichtet <sup>1)</sup>			$\mu m$	$\mu m$	$\mu m$	$\mu m$	$\mu m$		$\mu m$
0	2,5	0	-2,5	-	-	2,5	2,5	2,5	2,5	2,5	2,5	2,5	2,5	-	-	-	1,5	1,5	1,5	0,75	-	-	1,5			
2,5	6	0	-2,5	0	-2,5	2,5	2,5	2,5	2,5	2,5	2,5	2,5	2,5	-	-	-	1,5	1,5	1,5	1,5	-	-	1,5			
6	18	0	-2,5	0	-2,5	2,5	2,5	2,5	2,5	2,5	2,5	2,5	2,5	-	-	-	1,5	1,5	1,5	1,5	Identisch mit	-	1,5			
18	30	0	-4	0	-4	4	4	4	4	4	4	4	4	-	-	-	2	2,5	2,5	1,5	$\Delta Bs$ für den	-	1,5			
30	50	0	-4	0	-4	4	4	4	4	4	4	4	4	-	-	-	2	2,5	2,5	1,5	Innenring	-	1,5			
50	80	0	-4	0	-4	4	4	4	4	4	4	4	4	-	-	-	2	4	4	1,5	desselben	-	1,5			
80	120	0	-5	0	-5	5	5	5	5	5	5	5	5	-	-	-	2,5	5	5	2,5	Lagers	-	2,5			
120	150	0	-5	0	-5	5	5	5	5	5	5	5	5	-	-	-	2,5	5	5	2,5	-	-	2,5			
150	180	0	-7	0	-7	7	7	7	7	7	7	7	7	-	-	-	3,5	5	5	2,5	-	-	2,5			
180	250	0	-8	0	-8	8	8	8	8	8	8	8	8	-	-	-	4	7	7	4	-	-	4			
250	315	0	-8	0	-8	8	8	8	8	8	8	8	8	-	-	-	4	7	7	5	-	-	5			
315	400	0	-10	0	-10	10	10	10	10	10	10	10	10	-	-	-	5	8	8	7	-	-	7			

1) Für Lager mit Deck- oder Dichtscheiben sind keine Werte festgelegt.

2) Nur für Rillenkugellager.

Die Toleranzen innerhalb des gekennzeichneten Bereichs entspricht DIN 620 - 2 / P2

# WN001 - 1 / SP

## Radiallager (außer Kegelrollenlager) - metrisch

Innenring																								
d		$\Delta_{dmp}$		$\Delta_{ds}$		$V_{dp}$										$V_{dmp}$	$K_{ia}$	$S_{ia}$	$S_d$	$\Delta_{Bs}$		$\Delta_{B1s}$		$V_{Bs}$
über	bis	ob.	unt.	ob.	unt.	0	1	2	3	4	5	6	7	8	9	max.	max.	max.	max.	ob.	unt.	ob.	unt.	max.
mm		$\mu m$		$\mu m$		$\mu m$										$\mu m$	$\mu m$	$\mu m$	$\mu m$	$\mu m$		$\mu m$		$\mu m$
0	18	0	-5	0	-5	3	3	3	3	3	3	3	3	3	3	-	3	-	8	0	-100	-	-	5
18	30	0	-6	0	-6	3	3	3	3	3	3	3	3	3	3	-	3	-	8	0	-100	-	-	5
30	50	0	-8	0	-8	4	4	4	4	4	4	4	4	4	4	-	4	-	8	0	-120	-	-	5
50	80	0	-9	0	-9	5	5	5	5	5	5	5	5	5	5	-	4	-	8	0	-150	-	-	6
80	120	0	-10	0	-10	5	5	5	5	5	5	5	5	5	5	-	5	-	9	0	-200	-	-	7
120	180	0	-13	0	-13	7	7	7	7	7	7	7	7	7	7	-	6	-	10	0	-250	-	-	8
180	250	0	-15	0	-15	8	8	8	8	8	8	8	8	8	8	-	8	-	11	0	-300	-	-	10
250	315	0	-18	0	-18	9	9	9	9	9	9	9	9	9	9	-	8	-	13	0	-350	-	-	13
315	400	0	-23	0	-23	12	12	12	12	12	12	12	12	12	12	-	10	-	15	0	-400	-	-	15
400	500	0	-27	0	-27	14	14	14	14	14	14	14	14	14	14	-	10	-	17	0	-450	-	-	17
500	630	0	-30	0	-30	15	15	15	15	15	15	15	15	15	15	-	12	-	20	0	-500	-	-	20
630	800	0	-40	0	-40	20	20	20	20	20	20	20	20	20	20	-	15	-	23	0	-750	-	-	30
800	1000	0	-50	0	-50	25	25	25	25	25	25	25	25	25	25	-	17	-	30	0	-1000	-	-	33
1000	1250	0	-65	0	-65	33	33	33	33	33	33	33	33	33	33	-	20	-	40	0	-1250	-	-	40

Die Toleranzen innerhalb des gekennzeichneten Bereichs entspricht DIN 620

# WN001 - 1 / SP

## Radiallager (außer Kegelrollenlager) - metrisch

Außenring																									
D		$\Delta_{Dmp}$		$\Delta_{Ds}$		$V_{Dp}$										$V_{Dmp}$	$K_{ea}$	$S_{ea}$	$S_D$	$\Delta_{Cs}$		$V_{Cs}$			
über	bis	ob.	unt.	ob.	unt.	0	1	2	3	4	7	8	9	2	3	4	max.	max.	max.	max.	ob.	unt.	max.		
mm		$\mu m$		$\mu m$		offen										abgedichtet			$\mu m$	$\mu m$	$\mu m$	$\mu m$	$\mu m$		$\mu m$
30	50	0	-7	0	-7	4	4	4	4	4	4	4	4	-	-	-	-	5	-	8	-				
50	80	0	-9	0	-9	5	5	5	5	5	5	5	5	-	-	-	-	5	-	8	-				
80	120	0	-10	0	-10	5	5	5	5	5	5	5	5	-	-	-	-	6	-	9	Identisch mit				
120	150	0	-11	0	-11	6	6	6	6	6	6	6	6	-	-	-	-	7	-	10	$\Delta Bs$ und $V Bs$				
150	180	0	-13	0	-13	7	7	7	7	7	7	7	7	-	-	-	-	8	-	10	für Innenring				
180	250	0	-15	0	-15	8	8	8	8	8	8	8	8	-	-	-	-	10	-	11	desselben Lagers				
250	315	0	-18	0	-18	9	9	9	9	9	9	9	9	-	-	-	-	11	-	13	-				
315	400	0	-20	0	-20	10	10	10	10	10	10	10	10	-	-	-	-	13	-	13	-				
400	500	0	-23	0	-23	12	12	12	12	12	12	12	12	-	-	-	-	15	-	15	-				
500	630	0	-28	0	-28	14	14	14	14	14	14	14	14	-	-	-	-	17	-	17	-				
630	800	0	-35	-	-	18	18	18	18	18	18	18	18	-	-	-	-	20	-	20	-				
800	1000	0	-40	-	-	20	20	20	20	20	20	20	20	-	-	-	-	23	-	25	-				
1000	1250	0	-50	-	-	25	25	25	25	25	25	25	25	-	-	-	-	26	-	30	-				
1250	1600	0	-65	-	-	33	33	33	33	33	33	33	33	-	-	-	-	30	-	35	-				

Die Toleranzen innerhalb des gekennzeichneten Bereichs entspricht DIN 620



# WN001 - 1 / UP

## Radiallager (außer Kegelrollenlager) - metrisch

Innenring																								
d		$\Delta_{dmp}$		$\Delta_{ds}$		$V_{dp}$										$V_{dmp}$	$K_{ia}$	$S_{ia}$	$S_d$	$\Delta_{Bs}$		$\Delta_{B1s}$		$V_{Bs}$
über	bis	ob.	unt.	ob.	unt.	0	1	2	3	4	5	6	7	8	9	max.	max.	max.	max.	ob.	unt.	ob.	unt.	max.
mm		$\mu m$		$\mu m$		$\mu m$										$\mu m$	$\mu m$	$\mu m$	$\mu m$	$\mu m$		$\mu m$		$\mu m$
0	18	0	-4	0	-4	2	2	2	2	2	2	2	2	2	2	-	1,5	-	2	0	-25	-	-	1,5
18	30	0	-5	0	-5	2,5	2,5	2,5	2,5	2,5	2,5	2,5	2,5	2,5	2,5	-	1,5	-	3	0	-25	-	-	1,5
30	50	0	-6	0	-6	3	3	3	3	3	3	3	3	3	3	-	2	-	3	0	-30	-	-	2
50	80	0	-7	0	-7	3,5	3,5	3,5	3,5	3,5	3,5	3,5	3,5	3,5	3,5	-	2	-	4	0	-40	-	-	3
80	120	0	-8	0	-8	4	4	4	4	4	4	4	4	4	4	-	3	-	4	0	-50	-	-	3
120	180	0	-10	0	-10	5	5	5	5	5	5	5	5	5	5	-	3	-	5	0	-60	-	-	4
180	250	0	-12	0	-12	6	6	6	6	6	6	6	6	6	6	-	4	-	6	0	-75	-	-	5
250	315	0	-15	0	-15	8	8	8	8	8	8	8	8	8	8	-	4	-	6	0	-100	-	-	5
315	400	0	-19	0	-19	10	10	10	10	10	10	10	10	10	10	-	5	-	7	0	-100	-	-	6
400	500	0	-23	0	-23	12	12	12	12	12	12	12	12	12	12	-	5	-	8	0	-125	-	-	7
500	630	0	-26	0	-26	13	13	13	13	13	13	13	13	13	13	-	6	-	9	0	-125	-	-	8

Die Toleranzen innerhalb des gekennzeichneten Bereichs entspricht DIN 620

# WN001 - 1 / UP

## Radiallager (außer Kegelrollenlager) - metrisch

Außenring																										
D		$\Delta_{Dmp}$		$\Delta_{Ds}$		$V_{Dp}$											$V_{Dmp}$	$K_{ea}$	$S_{ea}$	$S_D$	$\Delta_{Cs}$		$V_{Cs}$			
über	bis	ob.	unt.	ob.	unt.	0	1	2	3	4	7	8	9	2	3	4	max.	max.	max.	max.	ob.	unt.	max.			
mm		$\mu m$		$\mu m$		offen											abgedichtet			$\mu m$	$\mu m$	$\mu m$	$\mu m$	$\mu m$		$\mu m$
30	50	0	-5	0	-5	3	3	3	3	3	3	3	3	-	-	-	-	3	-	2	-					
50	80	0	-6	0	-6	3	3	3	3	3	3	3	3	-	-	-	-	3	-	2	-					
80	120	0	-7	0	-7	4	4	4	4	4	4	4	4	-	-	-	-	3	-	3	Identisch mit					
120	150	0	-8	0	-8	4	4	4	4	4	4	4	4	-	-	-	-	4	-	3	$\Delta Bs$ und $V Bs$					
150	180	0	-9	0	-9	5	5	5	5	5	5	5	5	-	-	-	-	4	-	3	für Innenring					
180	250	0	-10	0	-10	5	5	5	5	5	5	5	5	-	-	-	-	5	-	4	desselben Lagers					
250	315	0	-12	0	-12	6	6	6	6	6	6	6	6	-	-	-	-	6	-	4	-					
315	400	0	-14	0	-14	7	7	7	7	7	7	7	7	-	-	-	-	7	-	5	-					
400	500	0	-17	0	-17	9	9	9	9	9	9	9	9	-	-	-	-	8	-	5	-					
500	630	0	-20	0	-20	10	10	10	10	10	10	10	10	-	-	-	-	9	-	6	-					
630	800	0	-25	-	-	13	13	13	13	13	13	13	13	-	-	-	-	11	-	7	-					

Die Toleranzen innerhalb des gekennzeichneten Bereichs entspricht DIN 620

**WN001 - 2 / P0**  
**Radiallager (außer Kegelrollenlager) - zöllig**

Innenring																								
d		$\Delta_{dmp}$		$\Delta_{ds}$		$V_{dp}$										$V_{dmp}$	$K_{ia}$	$S_{ia}$	$S_d$	$\Delta_{Bs}$		$\Delta_{B1s}$		$V_{Bs}$
über	bis	ob.	unt.	ob.	unt.	0	1	2	3	4	5	6	7	8	9	max.	max.	max.	max.	ob.	unt.	ob.	unt.	max.
mm		$\mu m$		$\mu m$		$\mu m$										$\mu m$	$\mu m$	$\mu m$	$\mu m$	$\mu m$		$\mu m$		$\mu m$
0	25,4	5	-5	-	-	10	10	10	10	10	10	10	10	10	10	-	10	15	-	0	-127	-	-	13
25,4	50,8	5	-8	-	-	10	10	10	10	10	10	10	10	10	10	-	10	20	-	0	-127	-	-	13
50,8	76,2	5	-8	-	-	13	13	13	13	13	13	13	13	13	13	-	15	32	-	0	-127	-	-	13
76,2	152,4	5	-8	-	-	18	18	18	18	18	18	18	18	18	18	-	20	38	-	0	-127	-	-	15
152,4	203,2	5	-13	-	-	33	33	33	33	33	33	33	33	33	33	-	25	51	-	0	-127	-	-	15
203,2	304,8	5	-13	-	-	33	33	33	33	33	33	33	33	33	33	-	30	51	-	0	-254	-	-	20
304,8	381	5	-20	-	-	51	51	51	51	51	51	51	51	51	51	-	38	64	-	0	-406	-	-	25

Die Toleranzen innerhalb des gekennzeichneten Bereichs entspricht DIN 620

# WN001 - 2 / P0 Radiallager (außer Kegelrollenlager) - zöllig

Außenring																										
D		$\Delta_{Dmp}$		$\Delta_{Ds}$		$V_{Dp}$											$V_{Dmp}$	$K_{ea}$	$S_{ea}$	$S_D$	$\Delta_{Cs}$		$V_{Cs}$			
über	bis	ob.	unt.	ob.	unt.	0	1	2	3	4	7	8	9	2	3	4	max.	max.	max.	max.	ob.	unt.	max.			
mm		$\mu m$		$\mu m$		offen											abgedichtet			$\mu m$	$\mu m$	$\mu m$	$\mu m$	$\mu m$		$\mu m$
0	25,4	-8	-18	-	-	10	10	10	10	10	10	10	10	-	-	-	-	10	15	-	-	-	13			
25,4	50,8	-8	-20	-	-	10	10	10	10	10	10	10	10	-	-	-	-	13	15	-	Identisch mit		13			
50,8	76,2	-13	-25	-	-	13	13	13	13	13	13	13	13	-	-	-	-	15	20	-	$\Delta Bs$ für den		13			
76,2	152,4	-20	-33	-	-	18	18	18	18	18	18	18	18	-	-	-	-	18	30	-	Innenring		15			
152,4	203,2	-33	-46	-	-	33	33	33	33	33	33	33	33	-	-	-	-	20	38	-	desselben		15			
203,2	304,8	-33	-46	-	-	33	33	33	33	33	33	33	33	-	-	-	-	25	51	-	Lagers		20			
304,8	381	-33	-58	-	-	51	51	51	51	51	51	51	51	-	-	-	-	30	51	-	-	-	25			
381	508	-33	-58	-	-	51	51	51	51	51	51	51	51	-	-	-	-	38	64	-	-	-	30			

Die Toleranzen innerhalb des gekennzeichneten Bereichs entspricht DIN 620

# WN001 - 3 / P0

## Kegelrollenlager - metrisch

Innenring																								
d		$\Delta_{dmp}$		$\Delta_{ds}$		$V_{dp}$	$V_{dmp}$	$K_{ia}$	$S_{ia}$	$S_d$	$\Delta_{Bs}$		$\Delta_{Ts}$		$\Delta_{T1s}$		$\Delta_{T2s}$							
über	bis	ob.	unt.	ob.	unt.	max.	max.	max.	max.	max.	ob.	unt.	ob.	unt.	ob.	unt.	ob.	unt.						
mm		$\mu m$		$\mu m$		$\mu m$	$\mu m$	$\mu m$	$\mu m$	$\mu m$	$\mu m$		$\mu m$		$\mu m$		$\mu m$							
0	10	0	-12	-	-	12	9	15	-	-	0	-120	200	0	100	0	100	0						
10	18	0	-12	-	-	12	9	15	-	-	0	-120	200	0	100	0	100	0						
18	30	0	-12	-	-	12	9	18	-	-	0	-120	200	0	100	0	100	0						
30	50	0	-12	-	-	12	9	20	-	-	0	-120	200	0	100	0	100	0						
50	80	0	-15	-	-	15	11	25	-	-	0	-150	200	0	100	0	100	0						
80	120	0	-20	-	-	20	15	30	-	-	0	-200	200	-200	100	-100	100	-100						
120	180	0	-25	-	-	25	19	35	-	-	0	-250	350	-250	150	-150	200	-100						
180	250	0	-30	-	-	30	23	50	-	-	0	-300	350	-250	150	-150	200	-100						
250	315	0	-35	-	-	35	26	60	-	-	0	-350	350	-250	150	-150	200	-100						
315	400	0	-40	-	-	40	30	70	-	-	0	-400	400	-400	200	-200	200	-200						
400	500	0	-45	-	-	45	34	80	-	-	0	-450	450	-450	225	-225	225	-225						
500	630	0	-60	-	-	60	40	90	-	-	0	-500	500	-500	-	-	-	-						
630	800	0	-75	-	-	75	45	100	-	-	0	-750	600	-600	-	-	-	-						
800	1000	0	-100	-	-	100	55	115	-	-	0	-1000	750	-750	-	-	-	-						
1000	1250	0	-125	-	-	125	65	130	-	-	0	-1250	900	-900	-	-	-	-						
1250	1600	0	-160	-	-	160	80	150	-	-	0	-1600	1050	-1050	-	-	-	-						
1600	2000	0	-200	-	-	200	100	170	-	-	0	-2000	1200	-1200	-	-	-	-						

Die Toleranzen innerhalb des gekennzeichneten Bereichs entspricht DIN 620 - 2 / P0

**WN001 - 3 / P0**  
**Kegelrollenlager - metrisch**

Außenring														
D		$\Delta_{Dmp}$		$\Delta_{Ds}$		$V_{Dp}$	$V_{Dmp}$	$K_{ea}$	$S_{ea}$	$S_{ea1}$	$S_D$	$\Delta_{Cs}$		
über	bis	ob.	unt.	ob.	unt.	max.	max.	max.	max.	max.	max.	ob.	unt.	
mm		$\mu m$		$\mu m$		$\mu m$	$\mu m$	$\mu m$	$\mu m$	$\mu m$	$\mu m$	$\mu m$		
0	18	0	-12	-	-	12	9	18	-	-	-	-	-	
18	30	0	-12	-	-	12	9	18	-	-	-	-	-	
30	50	0	-14	-	-	14	11	20	-	-	-	Identisch mit		
50	80	0	-16	-	-	16	12	25	-	-	-	$\Delta Bs$ für den		
80	120	0	-18	-	-	18	14	35	-	-	-	Innenring		
120	150	0	-20	-	-	20	15	40	-	-	-	desselben		
150	180	0	-25	-	-	25	19	45	-	-	-	Lagers		
180	250	0	-30	-	-	30	23	50	-	-	-	-	-	
250	315	0	-35	-	-	35	26	60	-	-	-	-	-	
315	400	0	-40	-	-	40	30	70	-	-	-	-	-	
400	500	0	-45	-	-	45	34	80	-	-	-	-	-	
500	630	0	-50	-	-	50	38	100	-	-	-	-	-	
630	800	0	-75	-	-	80	55	120	-	-	-	-	-	
800	1000	0	-100	-	-	100	75	140	-	-	-	-	-	
1000	1250	0	-125	-	-	130	90	160	-	-	-	-	-	
1250	1600	0	-160	-	-	170	100	180	-	-	-	-	-	
1600	2000	0	-200	-	-	210	110	200	-	-	-	-	-	
2000	2500	0	-250	-	-	265	120	220	-	-	-	-	-	

Die Toleranzen innerhalb des gekennzeichneten Bereichs entspricht DIN 620 - 2 / P0

# WN001 - 3 / P6X Kegelrollenlager - metrisch

Innenring																								
d		$\Delta_{dmp}$		$\Delta_{ds}$		$V_{dp}$	$V_{dmp}$	$K_{ia}$	$S_{ia}$	$S_d$	$\Delta_{Bs}$		$\Delta_{Ts}$		$\Delta_{T1s}$		$\Delta_{T2s}$							
über	bis	ob.	unt.	ob.	unt.	max.	max.	max.	max.	max.	ob.	unt.	ob.	unt.	ob.	unt.	ob.	unt.						
mm		$\mu m$		$\mu m$		$\mu m$	$\mu m$	$\mu m$	$\mu m$	$\mu m$	$\mu m$		$\mu m$		$\mu m$		$\mu m$							
0	10	0	-12	-	-	12	9	15	-	-	0	-50	100	0	50	0	50	0						
10	18	0	-12	-	-	12	9	15	-	-	0	-50	100	0	50	0	50	0						
18	30	0	-12	-	-	12	9	18	-	-	0	-50	100	0	50	0	50	0						
30	50	0	-12	-	-	12	9	20	-	-	0	-50	100	0	50	0	50	0						
50	80	0	-15	-	-	15	11	25	-	-	0	-50	100	0	50	0	50	0						
80	120	0	-20	-	-	20	15	30	-	-	0	-50	100	0	50	0	50	0						
120	180	0	-25	-	-	25	19	35	-	-	0	-50	150	0	50	0	100	0						
180	250	0	-30	-	-	30	23	50	-	-	0	-50	150	0	50	0	100	0						
250	315	0	-35	-	-	35	26	60	-	-	0	-50	200	0	100	0	100	0						
315	400	0	-40	-	-	40	30	70	-	-	0	-50	200	0	100	0	100	0						
400	500	0	-45	-	-	45	34	80	-	-	0	-50	200	0	100	0	100	0						

Die Toleranzen innerhalb des gekennzeichneten Bereichs entspricht DIN 620 - 2 / P6X

**WN001 - 3 / P6X**  
**Kegelrollenlager - metrisch**

Außenring														
D		$\Delta_{Dmp}$		$\Delta_{Ds}$		$V_{Dp}$	$V_{Dmp}$	$K_{ea}$	$S_{ea}$	$S_{ea1}$	$S_D$	$\Delta_{Cs}$		
über	bis	ob.	unt.	ob.	unt.	max.	max.	max.	max.	max.	max.	ob.	unt.	
mm		$\mu m$		$\mu m$		$\mu m$	$\mu m$	$\mu m$	$\mu m$	$\mu m$	$\mu m$	$\mu m$		
0	18	0	-12	-	-	12	9	18	-	-	-	0	-100	
18	30	0	-12	-	-	12	9	18	-	-	-	0	-100	
30	50	0	-14	-	-	14	11	20	-	-	-	0	-100	
50	80	0	-16	-	-	16	12	25	-	-	-	0	-100	
80	120	0	-18	-	-	18	14	35	-	-	-	0	-100	
120	150	0	-20	-	-	20	15	40	-	-	-	0	-100	
150	180	0	-25	-	-	25	19	45	-	-	-	0	-100	
180	250	0	-30	-	-	30	23	50	-	-	-	0	-100	
250	315	0	-35	-	-	35	26	60	-	-	-	0	-100	
315	400	0	-40	-	-	40	30	70	-	-	-	0	-100	
400	500	0	-45	-	-	45	34	80	-	-	-	-	-	
500	630	0	-50	-	-	50	38	100	-	-	-	-	-	

Die Toleranzen innerhalb des gekennzeichneten Bereichs entspricht DIN 620 - 2 / P6X



# WN001 - 3 / P5

## Kegelrollenlager - metrisch

Innenring																								
d		$\Delta_{dmp}$		$\Delta_{ds}$		$V_{dp}$	$V_{dmp}$	$K_{ia}$	$S_{ia}$	$S_d$	$\Delta_{Bs}$		$\Delta_{Ts}$		$\Delta_{T1s}$		$\Delta_{T2s}$							
über	bis	ob.	unt.	ob.	unt.	max.	max.	max.	max.	max.	ob.	unt.	ob.	unt.	ob.	unt.	ob.	unt.						
mm		$\mu m$		$\mu m$		$\mu m$	$\mu m$	$\mu m$	$\mu m$	$\mu m$	$\mu m$		$\mu m$		$\mu m$		$\mu m$							
0	10	0	-7	-	-	5	5	5	-	7	0	-200	200	-200	100	-100	100	-100						
10	18	0	-7	-	-	5	5	5	-	7	0	-200	200	-200	-	-	-	-						
18	30	0	-8	-	-	6	5	5	-	8	0	-200	200	-200	-	-	-	-						
30	50	0	-10	-	-	8	5	6	-	8	0	-240	200	-200	-	-	-	-						
50	80	0	-12	-	-	9	6	7	-	8	0	-300	200	-200	-	-	-	-						
80	120	0	-15	-	-	11	8	8	-	9	0	-400	200	-200	-	-	-	-						
120	180	0	-18	-	-	14	9	11	-	10	0	-500	350	-250	-	-	-	-						
180	250	0	-22	-	-	17	11	13	-	11	0	-600	350	-250	-	-	-	-						
250	315	0	-25	-	-	19	13	13	-	13	0	-700	350	-250	150	-150	200	-100						
315	400	0	-30	-	-	23	15	15	-	15	0	-800	400	-400	200	-200	200	-200						
400	500	0	-35	-	-	28	17	20	-	17	0	-900	450	-450	225	-225	225	-225						
500	630	0	-40	-	-	35	20	25	-	20	0	-1100	500	-500	-	-	-	-						
630	800	0	-50	-	-	45	25	30	-	25	0	-1600	600	-600	-	-	-	-						
800	1000	0	-60	-	-	60	30	37	-	30	0	-2000	750	-750	-	-	-	-						
1000	1250	0	-75	-	-	75	37	45	-	40	0	-2000	750	-750	-	-	-	-						
1250	1600	0	-90	-	-	90	45	55	-	50	0	-2000	900	-900	-	-	-	-						

Die Toleranzen innerhalb des gekennzeichneten Bereichs entspricht DIN 620 - 2 / P5

# WN001 - 3 / P5 Kegelrollenlager - metrisch

Außenring																											
D		$\Delta_{Dmp}$		$\Delta_{Ds}$		$V_{Dp}$	$V_{Dmp}$	$K_{ea}$	$S_{ea}$	$S_{ea1}$	$S_D$	$\Delta_{Cs}$															
über	bis	ob.	unt.	ob.	unt.	max.	max.	max.	max.	max.	max.	ob.	unt.														
mm		$\mu m$		$\mu m$		$\mu m$	$\mu m$	$\mu m$	$\mu m$	$\mu m$	$\mu m$	$\mu m$															
0	18	0	-8	-	-	6	5	6	-	-	4	-															
18	30	0	-8	-	-	6	5	6	-	-	8	-															
30	50	0	-9	-	-	7	5	7	-	-	8	Identisch mit															
50	80	0	-11	-	-	8	6	8	-	-	8	$\Delta Bs$ für den															
80	120	0	-13	-	-	10	7	10	-	-	9	Innenring															
120	150	0	-15	-	-	11	8	11	-	-	10	desselben															
150	180	0	-18	-	-	14	9	13	-	-	10	Lagers															
180	250	0	-20	-	-	15	10	15	-	-	11	-															
250	315	0	-25	-	-	19	13	18	-	-	13	-															
315	400	0	-28	-	-	22	14	20	-	-	13	-															
400	500	0	-33	-	-	26	17	24	-	-	8,5	-															
500	630	0	-38	-	-	30	20	30	-	-	10	-															
630	800	0	-45	-	-	38	25	36	-	-	12,5	-															
800	1000	0	-60	-	-	50	30	43	-	-	15	-															
1000	1250	0	-80	-	-	65	38	52	-	-	19	-															
1250	1600	0	-100	-	-	90	50	62	-	-	25	-															
1600	2000	0	-125	-	-	120	65	73	-	-	32,5	-															

Die Toleranzen innerhalb des gekennzeichneten Bereichs entspricht DIN 620 - 2 / P5

# WN001 - 3 / P4

## Kegelrollenlager - metrisch

Innenring																								
d		$\Delta_{dmp}$		$\Delta_{ds}$		$V_{dp}$	$V_{dmp}$	$K_{ia}$	$S_{ia}$	$S_d$	$\Delta_{Bs}$		$\Delta_{Ts}$		$\Delta_{T1s}$		$\Delta_{T2s}$							
über	bis	ob.	unt.	ob.	unt.	max.	max.	max.	max.	max.	ob.	unt.	ob.	unt.	ob.	unt.	ob.	unt.						
mm		$\mu m$		$\mu m$		$\mu m$	$\mu m$	$\mu m$	$\mu m$	$\mu m$	$\mu m$		$\mu m$		$\mu m$		$\mu m$							
0	10	-	-	0	-5	4	4	3	3	3	0	-200	200	-200	100	-100	100	-100						
10	18	0	-5	0	-5	4	4	3	3	3	0	-200	200	-200	-	-	-	-						
18	30	0	-6	0	-6	5	4	3	4	4	0	-200	200	-200	-	-	-	-						
30	50	0	-8	0	-8	6	5	4	4	4	0	-240	200	-200	-	-	-	-						
50	80	0	-9	0	-9	7	5	4	4	5	0	-300	200	-200	-	-	-	-						
80	120	0	-10	0	-10	8	5	5	5	5	0	-400	200	-200	-	-	-	-						
120	180	0	-13	0	-13	10	7	6	7	6	0	-500	350	-250	-	-	-	-						
180	250	0	-15	0	-15	11	8	8	8	7	0	-600	350	-250	-	-	-	-						
250	315	-	-	0	-18	12	9	9	9	8	0	-700	350	-250	150	-150	200	-100						

Die Toleranzen innerhalb des gekennzeichneten Bereichs entspricht DIN 620 - 2 / P4

## WN001 - 3 / P4 Kegelrollenlager - metrisch

Außenring																											
D		$\Delta_{Dmp}$		$\Delta_{Ds}$		$V_{Dp}$	$V_{Dmp}$	$K_{ea}$	$S_{ea}$	$S_{ea1}$	$S_D$	$\Delta_{Cs}$															
über	bis	ob.	unt.	ob.	unt.	max.	max.	max.	max.	max.	max.	ob.	unt.														
mm		$\mu m$		$\mu m$		$\mu m$	$\mu m$	$\mu m$	$\mu m$	$\mu m$	$\mu m$	$\mu m$															
0	18	-	-	0	-6	5	4	4	5	7	2	-															
18	30	0	-6	0	-6	5	4	4	5	-	4	-															
30	50	0	-7	0	-7	5	5	5	5	-	4	Identisch mit															
50	80	0	-9	0	-9	7	5	5	5	-	4	$\Delta Bs$ für															
80	120	0	-10	0	-10	8	5	6	6	-	5	Innenring															
120	150	0	-11	0	-11	8	6	7	7	-	5	desselben															
150	180	0	-13	0	-13	10	7	8	8	-	5	Lagers															
180	250	0	-15	0	-15	11	8	10	10	-	7	-															
250	315	0	-18	0	-18	14	9	11	10	-	8	-															
315	400	0	-20	0	-20	15	10	13	13	-	10	-															

Die Toleranzen innerhalb des gekennzeichneten Bereichs entspricht DIN 620 - 2 / P4

# WN001 - 3 / P2

## Kegelrollenlager - metrisch

Innenring																								
d		$\Delta_{dmp}$		$\Delta_{ds}$		$V_{dp}$	$V_{dmp}$	$K_{ia}$	$S_{ia}$	$S_d$	$\Delta_{Bs}$		$\Delta_{Ts}$		$\Delta_{T1s}$		$\Delta_{T2s}$							
über	bis	ob.	unt.	ob.	unt.	max.	max.	max.	max.	max.	ob.	unt.	ob.	unt.	ob.	unt.	ob.	unt.						
mm		$\mu m$		$\mu m$		$\mu m$	$\mu m$	$\mu m$	$\mu m$	$\mu m$	$\mu m$		$\mu m$		$\mu m$		$\mu m$							
0	10	-	-	0	-4	2,5	1,5	2	2	1,5	0	-200	200	-200	100	-100	100	-100						
10	18	-	-	0	-4	2,5	1,5	2	2	1,5	0	-200	200	-200	100	-100	100	-100						
18	30	-	-	0	-4	2,5	1,5	2,5	2,5	1,5	0	-200	200	-200	100	-100	100	-100						
30	50	-	-	0	-5	3	2	2,5	2,5	2	0	-240	200	-200	100	-100	100	-100						
50	80	-	-	0	-5	4	2	3	3	2	0	-300	200	-200	100	-100	100	-100						
80	120	-	-	0	-6	5	2,5	3	3	2,5	0	-400	200	-200	100	-100	100	-100						
120	180	-	-	0	-7	7	3,5	4	4	3,5	0	-500	200	-250	100	-100	100	-150						
180	250	-	-	0	-8	7	4	5	5	5	0	-600	200	-300	100	-150	100	-150						
250	315	-	-	0	-8	8	5	6	6	5,5	0	-700	200	-300	100	-150	100	-150						

Die Toleranzen innerhalb des gekennzeichneten Bereichs entspricht DIN 620

# WN001 - 3 / P2

## Kegelrollenlager - metrisch

Außenring																											
D		$\Delta_{Dmp}$		$\Delta_{Ds}$		$V_{Dp}$	$V_{Dmp}$	$K_{ea}$	$S_{ea}$	$S_{ea1}$	$S_D$	$\Delta_{Cs}$															
über	bis	ob.	unt.	ob.	unt.	max.	max.	max.	max.	max.	max.	ob.	unt.														
mm		$\mu m$		$\mu m$		$\mu m$	$\mu m$	$\mu m$	$\mu m$	$\mu m$	$\mu m$	$\mu m$															
0	18	-	-	0	-5	4	2,5	2,5	2,5	4	0,75	-															
18	30	-	-	0	-5	4	2,5	2,5	2,5	4	0,75	-															
30	50	-	-	0	-5	4	2,5	2,5	2,5	4	1	Identisch mit															
50	80	-	-	0	-6	4	2,5	4	4	6	1,25	$\Delta Bs$ für den															
80	120	-	-	0	-6	5	3	5	5	7	1,5	Innenring															
120	150	-	-	0	-7	5	3,5	5	5	7	1,75	desselben															
150	180	-	-	0	-7	7	4	5	5	7	2	Lagers															
180	250	-	-	0	-8	8	5	7	7	10	2,5	-															
250	315	-	-	0	-9	8	5	7	7	10	3	-															
315	400	-	-	0	-10	10	6	8	8	11	3,5	-															

Die Toleranzen innerhalb des gekennzeichneten Bereichs entspricht DIN 620

# WN001 - 3 / CL7C

## Kegelrollenlager - metrisch

Innenring																								
d		$\Delta_{dmp}$		$\Delta_{ds}$		$V_{dp}$	$V_{dmp}$	$K_{ia}$	$S_{ia}$	$S_d$	$\Delta_{Bs}$		$\Delta_{Ts}$		$\Delta_{T1s}$		$\Delta_{T2s}$							
über	bis	ob.	unt.	ob.	unt.	max.	max.	max.	max.	max.	ob.	unt.	ob.	unt.	ob.	unt.	ob.	unt.						
mm		$\mu m$		$\mu m$		$\mu m$	$\mu m$	$\mu m$	$\mu m$	$\mu m$	$\mu m$		$\mu m$		$\mu m$		$\mu m$							
10	18	0	-12	-	-	12	9	7	-	-	0	-120	200	0	100	0	100	0						
18	30	0	-12	-	-	12	9	8	-	-	0	-120	200	0	100	0	100	0						
30	50	0	-12	-	-	12	9	10	-	-	0	-120	200	0	100	0	100	0						
50	80	0	-15	-	-	15	11	10	-	-	0	-150	200	0	100	0	100	0						
80	120	0	-20	-	-	20	15	13	-	-	0	-200	200	-200	100	-100	100	-100						

Die Toleranzen innerhalb des gekennzeichneten Bereichs entspricht DIN 620

# WN001 - 3 / CL7C

## Kegelrollenlager - metrisch

Außenring																											
D		$\Delta_{Dmp}$		$\Delta_{Ds}$		$V_{Dp}$	$V_{Dmp}$	$K_{ea}$	$S_{ea}$	$S_{ea1}$	$S_D$	$\Delta_{Cs}$															
über	bis	ob.	unt.	ob.	unt.	max.	max.	max.	max.	max.	max.	ob.	unt.														
mm		$\mu m$		$\mu m$		$\mu m$	$\mu m$	$\mu m$	$\mu m$	$\mu m$	$\mu m$	$\mu m$															
10	18	0	-12	-	-	12	9	9	-	-	-	-															
18	30	0	-14	-	-	14	11	10	-	-	-	Identisch mit															
30	50	0	-16	-	-	16	12	13	-	-	-	$\Delta Bs$ für den															
50	80	0	-18	-	-	18	14	18	-	-	-	Innenring															
80	120	0	-20	-	-	20	15	20	-	-	-	desselben															
120	180	0	-25	-	-	25	19	23	-	-	-	Lagers															

Die Toleranzen innerhalb des gekennzeichneten Bereichs entspricht DIN 620



# WN001 - 3 / CLN Kegelrollenlager - metrisch

Innenring																								
d		$\Delta_{dmp}$		$\Delta_{ds}$		$V_{dp}$	$V_{dmp}$	$K_{ia}$	$S_{ia}$	$S_d$	$\Delta_{Bs}$		$\Delta_{Ts}$		$\Delta_{T1s}$		$\Delta_{T2s}$							
über	bis	ob.	unt.	ob.	unt.	max.	max.	max.	max.	max.	ob.	unt.	ob.	unt.	ob.	unt.	ob.	unt.						
mm		$\mu m$		$\mu m$		$\mu m$	$\mu m$	$\mu m$	$\mu m$	$\mu m$	$\mu m$		$\mu m$		$\mu m$		$\mu m$							
10	18	0	-12	-	-	12	9	15	-	-	0	-50	100	0	50	0	50	0						
18	30	0	-12	-	-	12	9	18	-	-	0	-50	100	0	50	0	50	0						
30	50	0	-12	-	-	12	9	20	-	-	0	-50	100	0	50	0	50	0						
50	80	0	-15	-	-	15	11	25	-	-	0	-50	100	0	50	0	50	0						
80	120	0	-20	-	-	20	15	30	-	-	0	-50	100	0	50	0	50	0						
120	180	0	-25	-	-	25	19	35	-	-	0	-50	150	0	50	0	100	0						
180	250	0	-30	-	-	30	23	50	-	-	0	-50	150	0	50	0	100	0						
250	315	0	-35	-	-	35	26	60	-	-	0	-50	200	0	100	0	100	0						
315	400	0	-40	-	-	40	30	70	-	-	0	-50	200	0	100	0	100	0						

     Die Toleranzen innerhalb des gekennzeichneten Bereichs entspricht DIN 620

**WN001 - 3 / CLN**  
**Kegelrollenlager - metrisch**

Außenring														
D		$\Delta_{Dmp}$		$\Delta_{Ds}$		$V_{Dp}$	$V_{Dmp}$	$K_{ea}$	$S_{ea}$	$S_{ea1}$	$S_D$	$\Delta_{Cs}$		
über	bis	ob.	unt.	ob.	unt.	max.	max.	max.	max.	max.	max.	ob.	unt.	
mm		$\mu m$		$\mu m$		$\mu m$	$\mu m$	$\mu m$	$\mu m$	$\mu m$	$\mu m$	$\mu m$		
10	18	0	-12	-	-	12	9	18	-	-	-	0	-100	
18	30	0	-14	-	-	14	11	20	-	-	-	0	-100	
30	50	0	-16	-	-	16	12	25	-	-	-	0	-100	
50	80	0	-18	-	-	18	14	35	-	-	-	0	-100	
80	120	0	-20	-	-	20	15	40	-	-	-	0	-100	
120	180	0	-25	-	-	25	19	45	-	-	-	0	-100	
180	250	0	-30	-	-	30	23	50	-	-	-	0	-100	
250	315	0	-35	-	-	35	26	60	-	-	-	0	-100	
315	400	0	-40	-	-	40	30	70	-	-	-	0	-100	
400	500	0	-45	-	-	45	34	80	-	-	-	0	-100	
500	630	0	-50	-	-	50	38	100	-	-	-	0	-100	

Die Toleranzen innerhalb des gekennzeichneten Bereichs entspricht DIN 620

**WN001 - 4 / P0**  
**Kegelrollenlager - zöllig**

Innenring																					
d		$\Delta_{ds}$		$\Delta_{Ts}$																	
über	bis	ob.	unt.	ob.	unt.																
mm		$\mu\text{m}$		$\mu\text{m}$																	
0	76,2	13	0	203	0																
76,2	101,6	25	0	203	0																
101,6	266,7	25	0	356	-254																
266,7	304,8	25	0	356	-254																
304,8	609,6	51	0	381	-381																
609,6	914,4	76	0	381	-381																
914,4	1219	102	0	-	-																
1219	1524	127	0	-	-																

**Die Toleranzen innerhalb des gekennzeichneten Bereichs entspricht DIN 620**

**WN001 - 4 / P0**  
**Kegelrollenlager - zöllig**

**Außenring**

D		$\Delta_{Ds}$		$K_{ia}$	$K_{ea}$	$S_{ia}$	$S_{ea}$														
über	bis	ob.	unt.	max.	max.	max.	max.														
mm		$\mu\text{m}$		$\mu\text{m}$	$\mu\text{m}$	$\mu\text{m}$	$\mu\text{m}$														
0	304,8	25	0	51	51	51	51														
304,8	609,6	51	0	51	51	51	51														
609,6	914,4	76	0	76	76	76	76														
914,4	1219	102	0	76	76	76	76														
1219	1524	127	0	76	76	76	76														

**Die Toleranzen innerhalb des gekennzeichneten Bereichs entspricht DIN 620**

**WN001 - 4 / CL2**  
**Kegelrollenlager - zöllig**

Innenring																					
d		$\Delta_{ds}$		$\Delta_{Ts}$																	
über	bis	ob.	unt.	ob.	unt.																
mm		$\mu\text{m}$		$\mu\text{m}$																	
0	76,2	13	0	203	0																
76,2	101,6	25	0	203	0																
101,6	266,7	25	0	203	0																
266,7	304,8	25	0	203	0																
304,8	609,6	51	0	381	-381																
609,6	914,4	76	0	-	-																
914,4	1219	102	0	-	-																
1219	1524	127	0	-	-																

**Die Toleranzen innerhalb des gekennzeichneten Bereichs entspricht DIN 620**

**WN001 - 4 / CL2**  
**Kegelrollenlager - zöllig**

Außenring																				
D		$\Delta_{Ds}$		$K_{ia}$	$K_{ea}$	$S_{ia}$	$S_{ea}$													
über	bis	ob.	unt.	max.	max.	max.	max.													
mm		$\mu\text{m}$		$\mu\text{m}$	$\mu\text{m}$	$\mu\text{m}$	$\mu\text{m}$													
0	304,8	25	0	38	38	38	38													
304,8	609,6	51	0	38	38	38	38													
609,6	914,4	76	0	51	51	51	51													
914,4	1219	102	0	-	-	-	-													
1219	1524	127	0	-	-	-	-													

         Die Toleranzen innerhalb des gekennzeichneten Bereichs entspricht DIN 620

**WN001 - 4 / CL3**  
**Kegelrollenlager - zöllig**

Innenring																				
d		$\Delta_{ds}$		$\Delta_{Ts}$																
über	bis	ob.	unt.	ob.	unt.															
mm		$\mu\text{m}$		$\mu\text{m}$																
0	76,2	13	0	203	-203															
76,2	101,6	13	0	203	-203															
101,6	266,7	13	0	203	-203															
266,7	304,8	13	0	203	-203															
304,8	609,6	25	0	381	-381															
609,6	914,4	38	0	381	-381															
914,4	1219	51	0	-	-															
1219	1524	76	0	-	-															

     Die Toleranzen innerhalb des gekennzeichneten Bereichs entspricht DIN 620

**WN001 - 4 / CL3**  
**Kegelrollenlager - zöllig**

Außenring																				
D		$\Delta_{Ds}$		$K_{ia}$	$K_{ea}$	$S_{ia}$	$S_{ea}$													
über	bis	ob.	unt.	max.	max.	max.	max.													
mm		$\mu\text{m}$		$\mu\text{m}$	$\mu\text{m}$	$\mu\text{m}$	$\mu\text{m}$													
0	304,8	13	0	8	8	8	8													
304,8	609,6	25	0	18	18	18	18													
609,6	914,4	38	0	51	51	51	51													
914,4	1219	51	0	76	76	76	76													
1219	1524	76	0	76	76	76	76													

         Die Toleranzen innerhalb des gekennzeichneten Bereichs entspricht DIN 620



**WN001 - 4 / CL0**  
**Kegelrollenlager - zöllig**

Innenring																				
d		$\Delta_{ds}$		$\Delta_{Ts}$																
über	bis	ob.	unt.	ob.	unt.															
mm		$\mu\text{m}$		$\mu\text{m}$																
0	76,2	13	0	203	-203															
76,2	101,6	13	0	203	-203															
101,6	266,7	13	0	203	-203															
266,7	304,8	13	0	203	-203															
304,8	609,6	25	0	381	-381															
609,6	914,4	38	0	381	-381															
914,4	1219	51	0	-	-															
1219	1524	76	0	-	-															

**Die Toleranzen innerhalb des gekennzeichneten Bereichs entspricht DIN 620**

**WN001 - 4 / CL0**  
**Kegelrollenlager - zöllig**

Außenring																					
D		$\Delta_{Ds}$		$K_{ia}$	$K_{ea}$	$S_{ia}$	$S_{ea}$														
über	bis	ob.	unt.	max.	max.	max.	max.														
mm		$\mu\text{m}$		$\mu\text{m}$	$\mu\text{m}$	$\mu\text{m}$	$\mu\text{m}$														
0	304,8	13	0	4	4	4	4														
304,8	609,6	25	0	9	9	9	9														
609,6	914,4	38	0	26	26	26	26														
914,4	1219	51	0	38	38	38	38														
1219	1524	76	0	-	-	-	-														

         Die Toleranzen innerhalb des gekennzeichneten Bereichs entspricht DIN 620

## WN001 - 5 / P0

### Kegelige Bohrung, Kegel 1:12 - metrisch

Innenring																				
d		$\Delta_{dmp}^{1)}$		$V_{dp}^{3)}$	$\Delta_{d1mp} \cdot \Delta_{dmp}^{2)}$															
über	bis	ob.	unt.	max.	ob.	unt.														
mm		$\mu m$		$\mu m$	$\mu m$															
0	10	15	0	10	15	0														
10	18	18	0	10	18	0														
18	30	21	0	13	21	0														
30	50	25	0	15	25	0														
50	80	30	0	19	30	0														
80	120	35	0	25	35	0														
120	180	40	0	31	40	0														
180	250	46	0	38	46	0														
250	315	52	0	44	52	0														
315	400	57	0	50	57	0														
400	500	63	0	56	63	0														
500	630	70	0	70	70	0														
630	800	80	0	-	80	0														
800	1000	90	0	-	90	0														
1000	1250	105	0	-	105	0														
1250	1600	125	0	-	125	0														
1600	2000	150	0	-	150	0														

1) Abweichung des mittleren Durchmessers am theoretischen engen Durchmesser der Bohrung.

2) Abweichung des mittleren Durchmessers am theoretischen großen Durchmessers der Bohrung minus der Abweichung des mittleren Durchmessers am theoretischen engen Durchmesser der Bohrung.

3) Gilt in beliebigen radialen Schnitten der Bohrung.

Die Toleranzen innerhalb des gekennzeichneten Bereichs entspricht DIN 620 - 2 / Kegel 1 : 12

# WN001 - 5 / P6

## Kegelige Bohrung, Kegel 1:12 - metrisch

Innenring																				
d		$\Delta_{dmp}^{1)}$		$V_{dp}^{3)}$	$\Delta_{d1mp} \cdot \Delta_{dmp}^{2)}$															
über	bis	ob.	unt.	max.	ob.	unt.														
mm		$\mu m$		$\mu m$	$\mu m$															
18	30	21	0	13	21	0														
30	50	25	0	15	25	0														
50	80	30	0	19	30	0														
80	120	35	0	25	35	0														
120	180	40	0	31	40	0														
180	250	46	0	38	46	0														
250	315	52	0	44	52	0														
315	400	57	0	50	57	0														
400	500	63	0	56	63	0														
500	630	70	0	70	70	0														
630	800	80	0	-	80	0														
800	1000	90	0	-	90	0														
1000	1250	105	0	-	105	0														
1250	1600	125	0	-	125	0														
1600	2000	150	0	-	150	0														

- 1) Abweichung des mittleren Durchmessers am theoretischen engen Durchmesser der Bohrung.
- 2) Abweichung des mittleren Durchmessers am theoretischen großen Durchmessers der Bohrung minus der Abweichung des mittleren Durchmessers am theoretischen engen Durchmesser der Bohrung.
- 3) Gilt in beliebigen radialen Schnitten der Bohrung.

**Die Toleranzen innerhalb des gekennzeichneten Bereichs entspricht DIN 620**

# WN001 - 5 / P5

## Kegelige Bohrung, Kegel 1:12 - metrisch

Innenring																				
d		$\Delta_{dmp}^{1)}$		$V_{dp}^{3)}$	$\Delta_{d1mp} \cdot \Delta_{dmp}^{2)}$															
über	bis	ob.	unt.	max.	ob.	unt.														
mm		$\mu m$		$\mu m$	$\mu m$															
18	30	13	0	13	13	0														
30	50	16	0	15	16	0														
50	80	19	0	19	19	0														
80	120	22	0	22	22	0														
120	180	25	0	25	25	0														
180	250	29	0	29	29	0														
250	315	32	0	32	32	0														
315	400	36	0	36	36	0														
400	500	40	0	-	40	0														
500	630	44	0	-	44	0														
630	800	50	0	-	50	0														
800	1000	56	0	-	56	0														
1000	1250	66	0	-	66	0														
1250	1600	78	0	-	78	0														
1600	2000	92	0	-	92	0														

- 1) Abweichung des mittleren Durchmessers am theoretischen engen Durchmesser der Bohrung.
- 2) Abweichung des mittleren Durchmessers am theoretischen großen Durchmessers der Bohrung minus der Abweichung des mittleren Durchmessers am theoretischen engen Durchmesser der Bohrung.
- 3) Gilt in beliebigen radialen Schnitten der Bohrung.

**Die Toleranzen innerhalb des gekennzeichneten Bereichs entspricht DIN 620**

## WN001 - 5 / SP Kegelige Bohrung, Kegel 1:12 - metrisch

Innenring																				
d		$\Delta_{dmp}^{1)}$		$V_{dp}^{3)}$	$\Delta_{d1mp} \cdot \Delta_{dmp}^{2)}$															
über	bis	ob.	unt.	max.	ob.	unt.														
mm		$\mu m$		$\mu m$	$\mu m$															
18	30	10	0	3	4	0														
30	50	12	0	4	4	0														
50	80	15	0	5	5	0														
80	120	20	0	5	6	0														
120	180	25	0	7	8	0														
180	250	30	0	8	10	0														
250	315	35	0	9	12	0														
315	400	40	0	12	12	0														
400	500	45	0	14	14	0														
500	630	50	0	18	15	0														
630	800	65	0	23	19	0														

1) Abweichung des mittleren Durchmessers am theoretischen engen Durchmesser der Bohrung.

2) Abweichung des mittleren Durchmessers am theoretischen großen Durchmessers der Bohrung minus der Abweichung des mittleren Durchmessers am theoretischen engen Durchmesser der Bohrung.

3) Gilt in beliebigen radialen Schnitten der Bohrung.

     Die Toleranzen innerhalb des gekennzeichneten Bereichs entspricht DIN 620

## WN001 - 5 / UP

### Kegelige Bohrung, Kegel 1:12 - metrisch

Innenring																				
d		$\Delta_{dmp}^{1)}$		$V_{dp}^{3)}$	$\Delta_{d1mp} \cdot \Delta_{dmp}^{2)}$															
über	bis	ob.	unt.	max.	ob.	unt.														
mm		$\mu m$		$\mu m$	$\mu m$															
18	30	6	0	2,5	2	0														
30	50	7	0	3	3	0														
50	80	8	0	3,5	3	0														
80	120	10	0	4	4	0														
120	180	12	0	5	4	0														
180	250	14	0	6	5	0														
250	315	15	0	8	6	0														
315	400	17	0	10	6	0														
400	500	19	0	12	7	0														
500	630	20	0	13	11	0														
630	800	22	0	17	13	0														

1) Abweichung des mittleren Durchmessers am theoretischen engen Durchmesser der Bohrung.

2) Abweichung des mittleren Durchmessers am theoretischen großen Durchmessers der Bohrung minus der Abweichung des mittleren Durchmessers am theoretischen engen Durchmesser der Bohrung.

3) Gilt in beliebigen radialen Schnitten der Bohrung.

**Die Toleranzen innerhalb des gekennzeichneten Bereichs entspricht DIN 620**

## WN001 - 6 / P0 Kegelige Bohrung, Kegel 1:30 - metrisch

Innenring																				
d		$\Delta_{dmp}^{1)}$		$V_{dp}^{3)}$	$\Delta_{d1mp} \cdot \Delta_{dmp}^{2)}$															
über	bis	ob.	unt.	max.	ob.	unt.														
mm		$\mu m$		$\mu m$	$\mu m$															
0	50	15	0	19	30	0														
50	80	15	0	19	35	0														
80	120	20	0	25	40	0														
120	180	25	0	31	50	0														
180	250	30	0	38	55	0														
250	315	35	0	44	60	0														
315	400	40	0	50	65	0														
400	500	45	0	56	75	0														
500	630	50	0	63	85	0														
630	800	75	0	-	100	0														
800	1000	100	0	-	100	0														
1000	1250	125	0	-	115	0														
1250	1600	160	0	-	125	0														

1) Abweichung des mittleren Durchmessers am theoretischen engen Durchmesser der Bohrung.

2) Abweichung des mittleren Durchmessers am theoretischen großen Durchmesser der Bohrung minus der Abweichung des mittleren Durchmessers am theoretischen engen Durchmesser der Bohrung.

3) Gilt in beliebigen radialen Schnitten der Bohrung.

     Die Toleranzen innerhalb des gekennzeichneten Bereichs entspricht DIN 620 - 2 / Kegel 1 : 30